

W43A Humidistat

The W43A Humidistat controls humidifying and/or dehumidifying equipment. Typical uses include the control of humidity by ventilation, air conditioning, humidifiers, and dehumidifiers in residential, commercial, and industrial installations.

The W43A has Single-Pole/Double-Throw (SPDT) snap-acting contacts rated to switch 1/4 hp motors. It has a wide setpoint range of 0 to 70% Relative Humidity (RH), as well as "off" dial positions for humidification and dehumidification. The differential of the W43A is fixed at approximately 6% RH.



Figure 1: W43A Humidistat with Vertical Faceplate

Features and Benefits

- | | |
|--|--|
| <input type="checkbox"/> Human Hair Sensing Element | Provides stable, accurate measurement |
| <input type="checkbox"/> 1/4 hp (6A) Rated Contacts | Permits direct operation of many fans in commercial applications |
| <input type="checkbox"/> High/Low Adjustable Knob Range Stops | Allows adjustments within a desired range |
| <input type="checkbox"/> Enclosed Pennswitch | Provides dust protection for contacts |
| <input type="checkbox"/> Mounting Plate | Allows easy mounting and wiring without removing the cover |

Introduction

IMPORTANT: The W43A Humidistat is designed for use **only** as an operating control. Where an operating control failure would result in personal injury and/or loss of property, it is the responsibility of the installer to add devices (safety, limit controls) or systems (alarm, supervisory systems) that protect against, or warn of, control failure.

The W43A Humidistat provides SPDT control for use on low or line voltage applications. It has a thermoplastic cover with Allen-head locking screw to discourage unauthorized tampering. The sensing element consists of carefully selected and processed human hair.

An adjusting knob and easy-to-read dial allow quick selection of the desired setpoint. The humidistat is supplied with the faceplate installed for vertical mounting and knob adjustment. However, a horizontal faceplate is enclosed for horizontal mounting and knob adjustment if desired.

Humidity Settings

The humidistat has a setpoint range of 0 to 70% RH, as well as humidification off (HUM OFF) and dehumidification off (DEH OFF) positions. At the HUM OFF position, the C to L terminal circuit is open and the C to H terminal circuit is closed.

At the DEH OFF position, the C to H terminal circuit is open and the C to L terminal controls the humidification equipment.

At any given setpoint, the C to L circuit closes on a decrease in relative humidity, and the C to H circuit closes on an increase in relative humidity.

The usual setting in winter is 30 to 40% RH. Lower settings may be necessary in extremely cold weather to prevent condensation on windows, doors, etc. The same setting should be used where reduction of humidity by means of exhaust fans is provided in well-constructed homes. Summer settings on air conditioning or dehumidifying equipment will usually be near 50% RH.

The suggested indoor humidity at 70°F (21°C) for residential applications on humidifying or dehumidifying equipment in winter is shown in Table 1.

Table 1: Humidity Settings

Outside Temperature	Suggested Humidity Setting
-20°F (-29°C) and Below	15% RH
-10°F (-23°C)	20% RH
0°F (-18°C)	25% RH
10°F (-12°C)	30% RH
20°F (-7°C)	35% RH
Above 20°F (-7°C)	40% RH or Higher as Desired

Installation

Supplies Needed

- 2 x 4 in. (51 x 102 mm) wall box (field supplied)
- 3-wire cable (field supplied)
- screwdriver (slotted standard)
- marking pencil
- wire strippers

Location Considerations

Locate the W43A Humidistat as follows:

- on an inside wall away from ranges, sinks, bathrooms, or other areas of extreme moisture and temperature
- where natural air circulation is unrestricted
- where lamps, sunlight, fireplaces, heat registers, radiators, concealed air ducts or pipes, or room occupants will not affect its operation

Dimensions

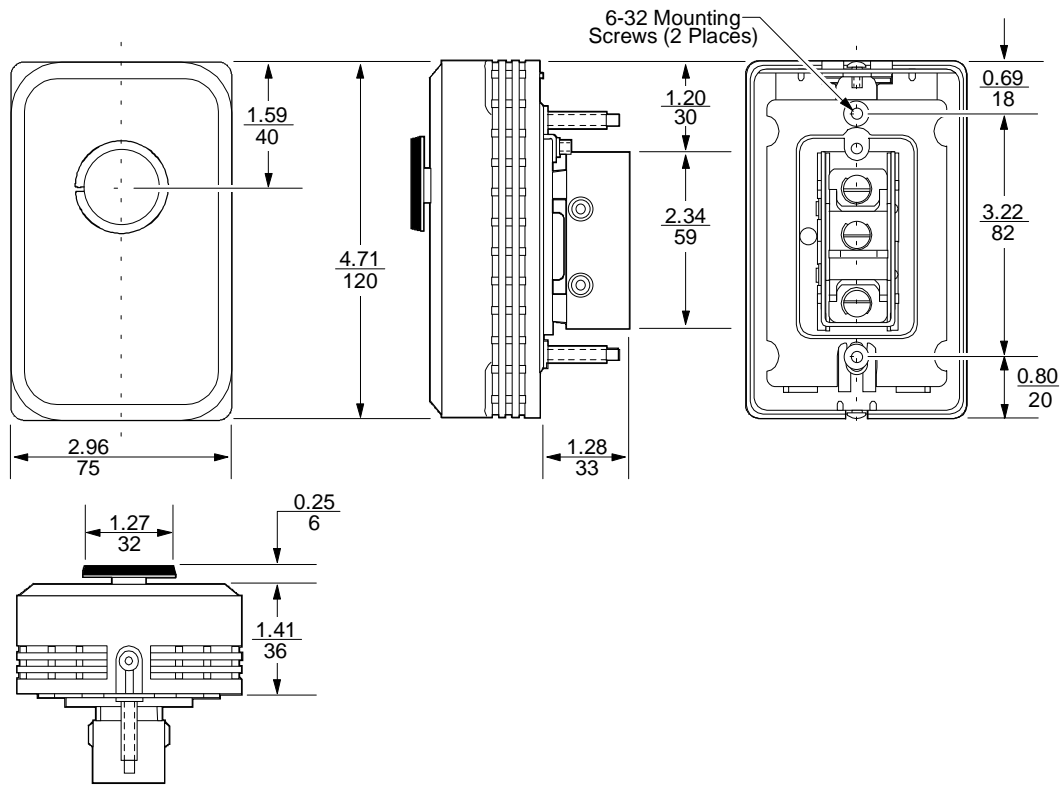

Figure 2: W43A Dimensions (in./mm)

Mounting and Wiring

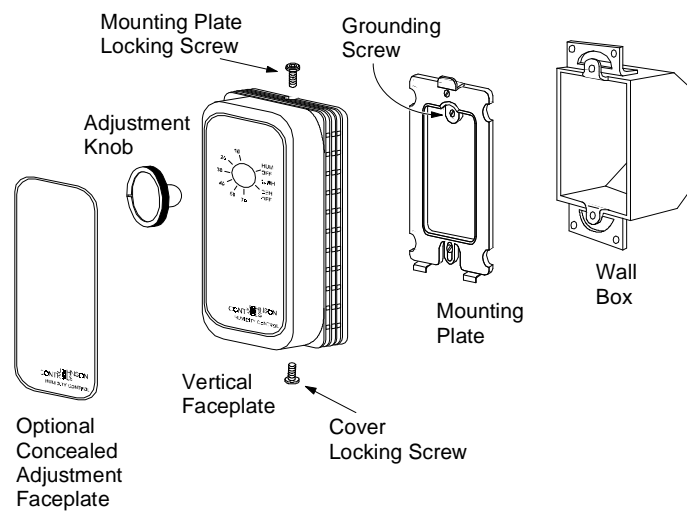

Figure 3: W43A Humidistat

IMPORTANT: Do not remove the humidistat cover during installation. The sensing element must be carefully protected against accidental damage. All wiring and mounting can be completed without removing the cover.



CAUTION: Shock hazard. Disconnect power supply before wiring connections are made to prevent electrical shock or possible damage to the equipment.

To mount the W43A Humidistat:

1. Select the proper mounting location (refer to the *Location Considerations* section) and install a vertical or horizontal wall box 4 to 5 feet (1.2 to 1.5 m) above the floor.
2. Run conduit or cable, as required by national and/or local electric codes, from the wall box to the equipment to be controlled. Leave approximately 6 in. (152 mm) of wire for connection to the humidistat terminals.
3. Remove the humidistat mounting plate by loosening the mounting plate locking screw (see Figure 3), and lifting and removing the plate from the base.
4. Pull wires through the mounting plate and fasten the plate, grounding screw end up, to the wall box with the screws provided.
5. Strip the wires and connect to the proper terminals on the back of the humidistat. See *Wiring Diagrams* section.

Note: Use the terminal screws furnished (8-32 x 1/4 in. binder head). Substitution of other screws may cause problems in making proper connections.
6. Connect the grounding provision of the humidistat to the branch circuit ground.
7. Hook the two slots in the humidistat base over the projections on the mounting plate and swing the humidistat into place. Push the wires back flush into the wall box.
8. Securely tighten the mounting plate locking screw.

Optional Horizontal Faceplate Installation

1. Mount and wire the humidistat according to the steps outlined in the *Installation* section.
2. Pull the adjustment knob off the humidistat cover.
3. Peel off the backing of the horizontal faceplate.
4. Position the horizontal faceplate over the factory-installed vertical faceplate. Be sure to position the plate straight and even over the existing plate.
5. Firmly press the horizontal faceplate onto the humidistat cover.
6. Replace the adjustment knob.

Wiring Diagrams

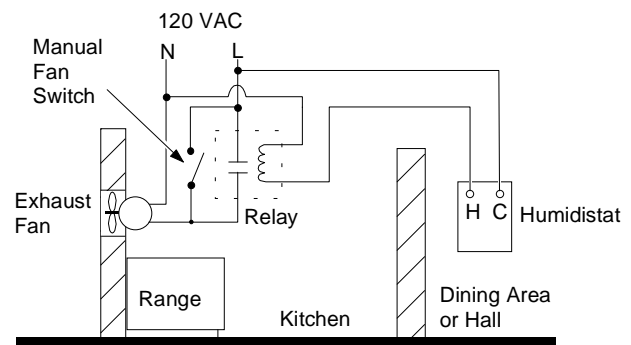

Figure 4: Typical Wiring Diagram of a W43A Used to Reduce Excessive Humidity in a Well-Constructed Building by Manual or Automatic Control of Exhaust Fan

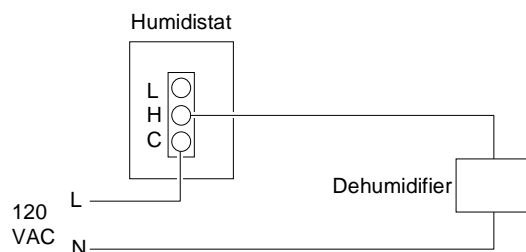

Figure 5: Dehumidification Control Wiring Diagram

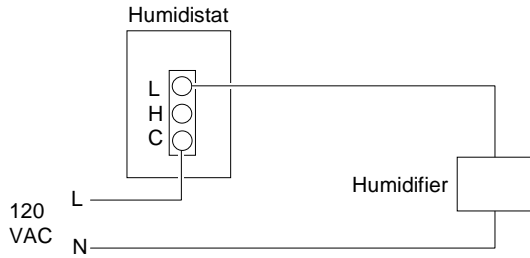

Figure 6: Humidification Control Wiring Diagram

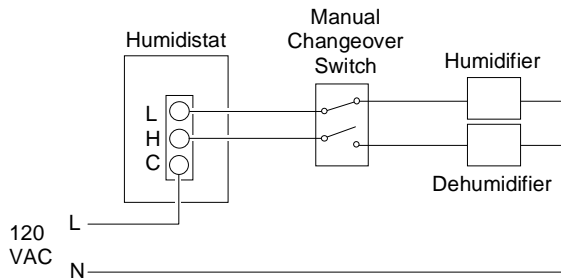

Figure 7: Schematic Wiring Diagram of a W43A Automatically Operating a Humidifier or Dehumidifier as Selected by Manual Changeover Switch

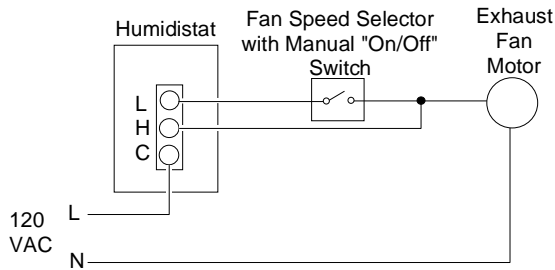

Figure 8: Schematic Wiring Diagram of a W43A Automatically Operating an Exhaust Fan at Full Speed to Control Excessive Humidity; a Combination Speed Control and "On/Off" Switch Permits Manual Operation of Exhaust Fan at Selected Speeds

Range Stops

High and low range stops of the humidistat can be field adjusted as desired. Use the following procedures to set the high and low range stops.

High Range Stop

1. Set the adjustment knob to the maximum desired RH setting.
2. Pull the adjustment knob off the humidistat cover.
3. Loosen the bottom cover screw and remove the humidistat cover.



CAUTION: Equipment damage hazard.
Avoid contact with human hair sensing element. Contact with hair element can affect control accuracy and/or product life.

4. While holding the dial firmly in place, keeping the setting in line with the calibrating mark, depress the tab "A" (see Figure 9) and rotate it counterclockwise until it is against the stop pin "C".
5. Release the tab making sure it fits into the nearest notch.
6. Replace the humidistat cover, tighten the bottom cover screw, and replace the adjustment knob.
7. Rotate adjustment knob to desired normal operating setpoint.

Low Range Stop

1. Set the adjustment knob to the minimum desired RH setting.
2. Pull the adjustment knob off the humidistat cover.
3. Loosen the bottom cover screw and remove the humidistat cover.



CAUTION: Equipment damage hazard.

Avoid contact with human hair sensing element. Contact with hair element can affect control accuracy and/or product life.

4. While holding the dial firmly in place, keeping the setting in line with the calibrating mark, depress the tab "B" (see Figure 9) and rotate it clockwise until it is against the stop pin "C".
5. Release the tab making sure it fits into the nearest notch.
6. Replace the humidistat cover, tighten the bottom cover screw, and replace the adjustment knob.
7. Rotate adjustment knob to desired normal operating setpoint.

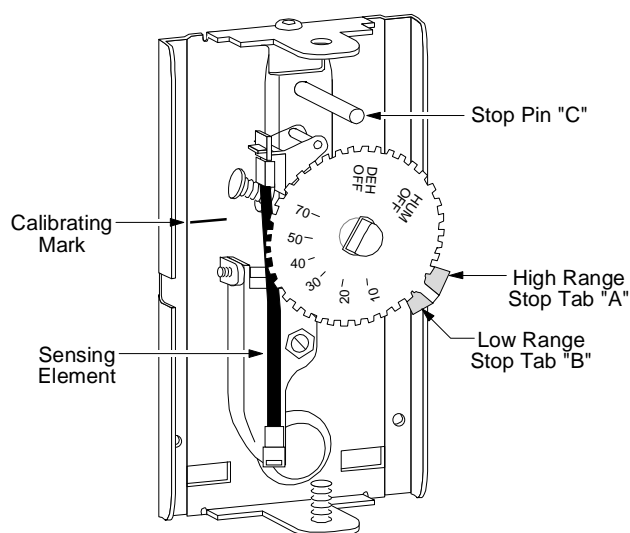

Figure 9: W43A Humidistat Range Tabs and Stop

Dial Lock

The high range stop and low range stop can be set to keep the adjustment knob from rotating. To lock the dial:

1. Set the adjustment knob to the desired RH setting.
2. Pull the adjustment knob off the humidistat cover.
3. Loosen the bottom cover screw and remove the humidistat cover.



CAUTION: Equipment damage hazard.

Avoid contact with human hair sensing element. Contact with hair element can affect control accuracy and/or product life.

4. While holding the dial firmly in place, keeping the setting in line with the calibrating mark, depress the tab "A" and rotate it counterclockwise until it is against the stop "C". Depress the tab "B" and rotate it clockwise until it is against the stop pin "C". See Figure 9.
5. Make sure each tab fits into the notch closest to the stop.
6. Replace the humidistat cover, tighten the bottom cover screw, and replace the adjustment knob.

Checkout Procedure

Before applying power, make sure installation and wiring connections are according to job specifications.

After all necessary adjustments and electrical connections have been made, put the system into operation and observe at least three complete operating cycles before leaving the installation.

Repairs and Replacement

Field repairs must not be made except for replacement of the adjustment knob or mounting plate. Refer to *Table 4: Replacement Parts* for replacement part ordering information. For a replacement W43A, contact the nearest Johnson Controls representative.

Ordering Information

Table 2: Ordering Information

Item	Product Code Number
Humidistat	W43A-14C

Accessories

Brand Name Faceplates

Brand name faceplates are available on quantity orders. Contact Customer Service.

Humidistat Guards

Plastic, wire, or cast aluminum guards are available at extra cost. See the GRD Series in the *Johnson Controls HVAC/Refrigeration Controls Catalog*.

Concealed Adjustment Faceplates

Concealed adjustment faceplates are available on factory order at no extra cost. For field changeover, use the concealed faceplate kit and install directly over the faceplate on the cover. See Table 3 for ordering information.

Table 3: Optional Accessories

Item	Product Code Number
Concealed Adjustment Faceplate, Vertical Mounting	PLT333-12R
Concealed Adjustment Faceplate, Horizontal Mounting	PLT333-9R

Replacement Parts

Table 4: Replacement Parts

Item	Product Code Number
Thermoplastic Push On Adjustment Knob	KNB26A-600R
Humidistat Mounting Plate	PLT51A-602R

Specifications

Product	W43A-14C Humidistat			
Contact Ratings		120 VAC	208 VAC	240 VAC
	Full Load Ampere	6.0	3.5	3.0
	Locked Rotor Ampere	36.0	21.0	18.0
	Pilot Duty 125 VA at 24/277 VAC			
Measurement Range	0 to 70% RH			
Differential	Fixed at approximately 6% RH			
Contact Action	SPDT			
Switch	Snap-acting Contacts in a Dust-protected Enclosure			
Sensing Element	Selected Human Hair			
Material	Base:	0.050 in (1.27 mm) Cold Rolled Steel		
	Cover:	Beige Thermoplastic		
Finish	Base:	Zinc Plate Dichromate Dipped		
	Cover:	Brown Markings on Gold Anodized Aluminum		
Mounting	Vertical or Horizontal 2 x 4 in. (51 x 102 mm) Wall Box			
Wiring Terminals	Large 8-32 x 1/4 in. Binder Head Screws			
Minimum Ambient Temperature	40° (4.4°C)			
Maximum Ambient Temperature	100°F (38°C)			
Agency Listings	UL Guide No. XAPX; File E6688 CSA Class No. 4813 02; File LR948			
Dimensions (H x W x D)	4.71 x 2.96 x 2.94 in. (120 x 75 x 75 mm)			
Shipping Weight	0.9 lb (0.4 kg)			

The performance specifications are nominal and conform to acceptable industry standards. For application at conditions beyond these specifications, consult the local Johnson Controls office. Johnson Controls, Inc. shall not be liable for damages resulting from misapplication or misuse of its products.



Controls Group
507 E. Michigan Street
P.O. Box 423
Milwaukee, WI 53201

Printed in U.S.A.